

Gear Pump 201

GP-201 is a self-priming, electric, gear pump for discontinuous or intermittent use. Low version transfers oil and high version transfers diesel or water. Nickel-plated brass body and helical bronze gears for constant pressure.

Basic Features

- Low flow
- Self-priming
- Reversible flow
- 12V or 24V
- IP67 rated

Compatible Fluids

- Low Version - Oil with viscosity < 350 cSt
- High Version - Diesel (min flash point 100°F / 35°C) and fresh water (max 185°F / 85°C)



Technical Specifications

Version	Low	High
Flow Rate (1/2" I.D. hose)	0.9 GPM 3.4 LPM	2.6 GPM 10 LPM
Voltage	12 or 24V	12 or 24V
Ports	3/8" BSPP with 3/8" Male NPT fittings	
Max. Work Pressure	22 psi / 1.5 bar	
Ambient Temperature	Min. 14°F / -10°C Max. 140°F / 60°C	
Amperage Draw	2.5A / 12V 1.3A / 24V	3A / 12V 1.5A / 24V
Fuse	3A / 12V 1.5A / 24V	5A / 12V 3A / 24V
Pump Type	Gear	
Body	Nickel-plated brass	
Shaft	Stainless steel	
Self-Priming	4.9 ft / 1.5 m (wet gears)	
Compatible Fluids	Oil with viscosity < 350 cSt	Diesel (min flash point 100°F / 35°C) Fresh water (max 185°F / 85°C)
Dimensions	A	5" / 128 mm
	B	4.4" / 112 mm
	C	3" / 76 mm
Weight	2.6 lbs / 1.2 kg	

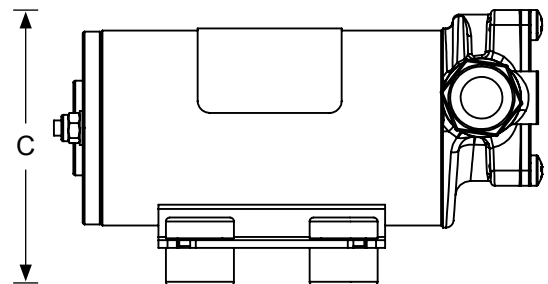
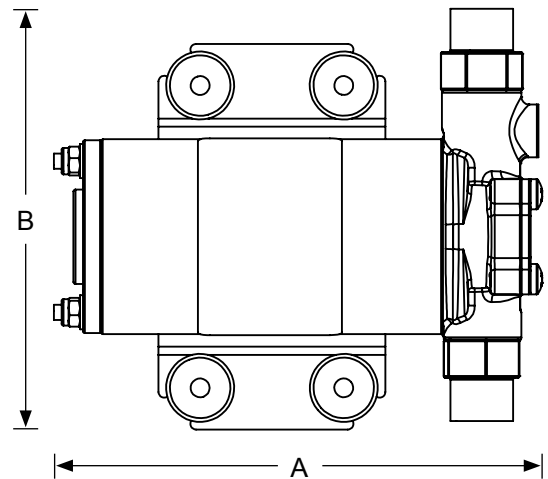

Operating Cycle

The pump has been designed for discontinuous use. Under conditions of high operating pressures (e.g. with closed or blocked outlet, excessive length of the delivery circuit and/or excessive pressure due to accessories), it can be subjected to elevated stresses and overheating and therefore should not be used for prolonged periods under such conditions.

Ambient Conditions

Indicated temperature ranges are applicable to all components of the pump and these limits must be adhered to in order to avoid any possible damage or malfunctioning.

Temperature Min. 14°F / -10°C

Temperature Max. 140°F / 60°C

Relative Humidity Max. 90%

Installation

The pump can be mounted in any position, except with the pump head above the pump motor. Always mount pump with the anti-vibration rubber mounts supplied with the pump.

Mount the pump within 4.9 ft / 1.5m above the lowest level of fluid.

The flow rate value indicated is obtained with internal pipe diameter 1/2". Piping with smaller diameters will cause an increase in current with potential risk of motor overheating.

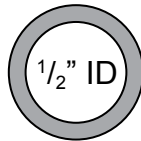

Electrical Connection

The electrical installation of this product must be executed by a qualified electrician and following the industry requirements. Be sure that the power source available matches the power requirements on the specification sheet for this product model.

The electrical installation of the pump must include a protection fuse which is suitable rated. Electrical wires should depend on the distance between the pump and battery power supply. The user of undersized wire can cause overheating of the electrical wiring and subsequent fire hazard. There will also be a voltage drop at the motor terminals with a consequent reduction in efficiency.

Up to 6.6 ft / 2m length of AWG 18.

Flow Direction

Connect red wire to (+) and black wire to (-), then flow is left to right.

Connect black wire to (+) and red wire to (-), then flow is right to left.

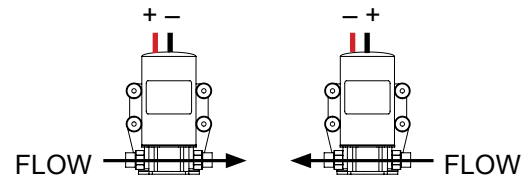

Good Practices

If it is expected that the pump will not be used for a period of at least 30 days, especially in the case of usage with water, it is advisable to run fresh water through it and to then loosen the front plate screws. Upon re-use, run the pump briefly (a few seconds) and tighten the screws again. Check under conditions of maximum operating temperature that the motor current value is within specifications.

Maintenance

- Frequently check inlet filter is clean (if installed).
- Every month, check the chamber and keep clean of any foreign matter.
- Every month, check electrical wiring is in good condition.

If Pump Is Not Priming, Check For:

- Excessive height above the fluid level.
- Pump has run dry for too long.
- Long periods of inactivity. In this case, it is advisable to add liquid directly into the pump head before startup. Also, before running the pump, add a drop of lubrication oil inside the pump only.
- Air leak in suction pipe due to possible cuts in the pipe, inadequate hose clamps, malfunctioning of the filter due to defective/worn seals or filter clogged.
- Air leak at the cover plate due to loose screws or poor effectiveness of the seal.
- Faulty electrical wire connections.
- Obstructions or restrictions in the suction or delivery pipes, or the use of special devices (e.g. automatic nozzle).
- Presence of liquid loops in the outlet tube.