

# FPS-2000

The Fuel Polishing System removes water, bacterial growth, and other particulate from diesel that are detrimental to fuel systems and thereby resolving many issues related to degraded fuel.

## Basic Features

- Separ Filter fuel water separator
- 30 micron paper element installed
- Touchscreen digital control
- Variable speed control
- Flow meter
- Safety shutdown and alarm for high vacuum, high pressure, and water
- Removable side panels
- Automatic filter water drain
- Spill sensor
- 1 1/2" Full port valves (inlet and outlet side)
- Stainless steel piping
- Secure access door (with key)
- Emergency stop button



## Technical Specifications

<b>Flow Range</b>	1,600 GPH - 2,000 GPH 6,057 LPH - 7,571 LPH	
<b>Inlet / Outlet</b>	1 1/2" Flange	
<b>Voltage Available</b>	110, 220, 208, 480 volt 60 Hz and 220, 380 volt 50 Hz	
<b>Amp. Draw</b>	Full Load	
<b>Circuit Breaker</b>	15A	
<b>Pump</b>	Vane	
<b>Water Drain Pump</b>	Gear	
<b>Suction Capability</b>	15 ft vertical lift (1 1/2" lines)	
<b>Dimensions</b>	A	36.5" / 927 mm
	B	49" / 1,245 mm
	C	32.5" / 826 mm
<b>Weight</b>	345 lbs / 156.5 kg	

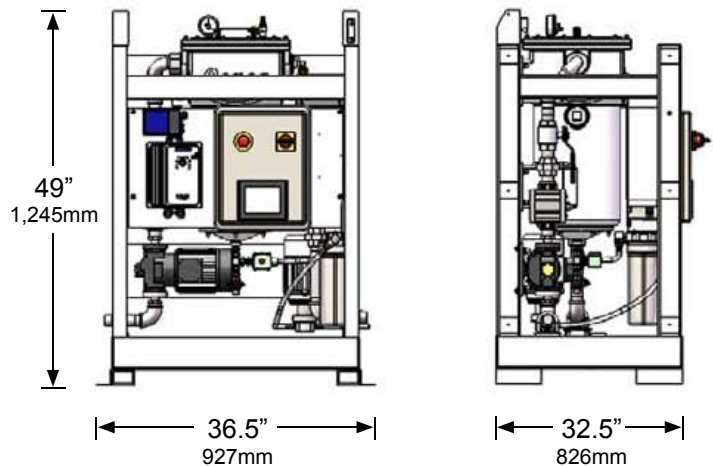

## Replacement Elements

<b>01810*</b>	10 micron
<b>01830*</b>	30 micron
<b>01860S*</b>	60 micron, stainless steel
*SWK-2000/130MK filter requires 4 elements	