

DP Series

High Flow Liquid Transfer Pump

Adjustable Flow: 15-32 GPM (56.8-121.1 LPM)

- Ideal for high flow diesel transfer
- Self-priming after initial fill
- Available AC or DC powered
- Reversible flow and precise flow control for AC versions

Top View: Pump must be mounted in horizontal position ONLY.

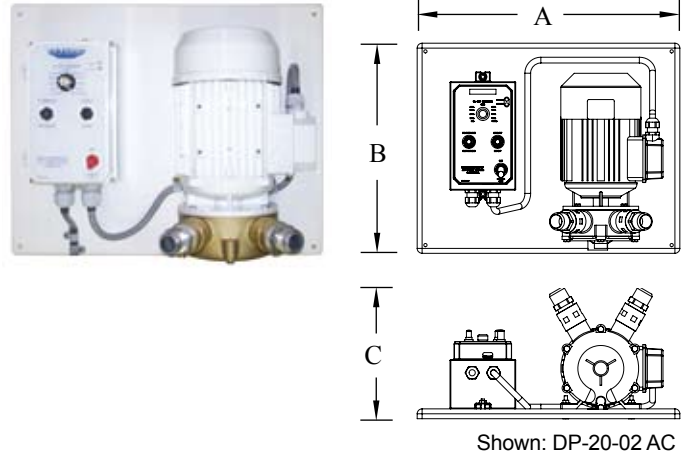

Technical Specification

	DP 15 DC/AC	DP 20 DC/AC	DP 30 DC/AC
Ports	#16 Male JIC	#16 Male JIC	#20 Male JIC
Max lift	39'/60'	60'/60'	72'/72'
Fluid temperature	32°F - 158°F (0°C - 70°C)		
Flow Rate at 0° level	15 GPM (56.8 LPM)	20GPM (75.7 LPM)	32 GPM (121.1 LPM)
Self priming	18 ft (5.5 m)	20 ft (6.1 m)	20 ft (6.1 m)
Pump body	Bronze		
Impeller	Bronze		
Shaft	316 Stainless steel		
Seal	Corrosion-proof NBR, w/ bronze spring		
Motor	DC/AC single phase	DC/AC single phase or 3-phase	DC/AC single phase or 3-phase
Continuous Duty	Yes		

Amperage

	DP 15	DP 20	DP 30
DC	24V@22A	24V@28A	24V@45A
AC	110/220V@10A 50/60Hz@10A	110/220V@10A 50/60Hz@10A	110/220V@15A 50/60Hz@15A

Weight

	Motor	Controller
DP-15-AC	20 lbs (9.07 kg)	8 lbs (3.6 kg)
DP-15-DC	22 lbs (10 kg)	N/A
DP-20-AC	28 lbs (12.7 kg)	8 lbs (3.6 kg)
DP-20-DC	32 lbs (14.5 kg)	N/A
DP-30-AC	42 lbs (19 kg)	12 lbs (5.5 kg)
DP-30-DC	46 lbs (21 kg)	N/A

Ordering Specifications

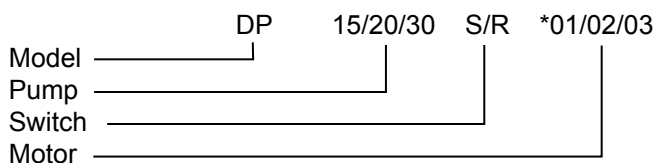

*Power Option: 01 (110v), 02 (220v), and 03 (24v)

Model-AC	A	B	C
DP-15-AC	14" (355.6mm)	14" (355.6mm)	8.19" (208mm)
DP-20-AC	20" (508mm)	16" (406.4mm)	9.75" (247.7mm)
DP-30-AC	20" (508mm)	18" (457.2mm)	7.95" (201.5mm)

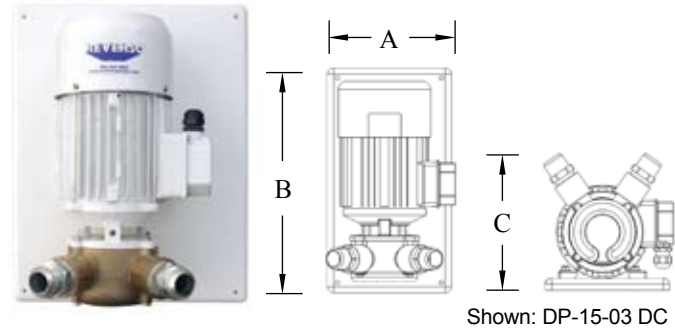

Model-DC	A	B	C
DP-15-DC	7.75" (196.9mm)	14" (355.6mm)	8.19" (208mm)
DP-20-DC	11" (279.4mm)	15" (381mm)	9.75" (247.7mm)
DP-30-DC	12" (304.8mm)	20" (508mm)	7.95" (201.5mm)

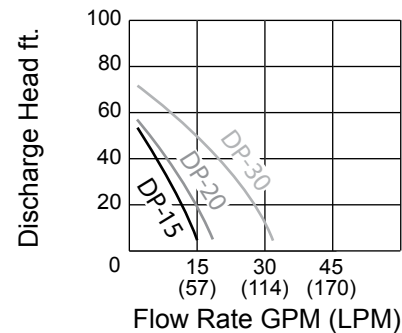

Drawing dimensions for reference only
Technical drawings available upon request.