

Oil Change System with Impeller Pump

Reverso has been the premier maker of oil change systems for over 20 years. This product is installed as standard equipment by a majority of boat builders.

- Reversible (Drains and fills engines)
- Self-priming
- Chrome plated brass head
- Built-in switch guard
- Easily changed impeller
- "CE" certified
- Available with valve options 2 - 6

Technical Specification

Pump Port	1/2" Flare
Manifold Ports	1/2" FNPT
Amp. Draw	7.0A@12v, 3A@24v
Flow Rate	2 GPM (7.57 LPM)
Self priming	3 ft (0.91 m)
Lift	10 ft (3.05 m)
Pump body	Nickel Brass
Impeller	Nitrile (Standard)
Working Pressure	0 to 15 psi
Seal	Nitrile Rubber
Motor	12V or 24V DC
Fuse	15A@12V, 10A@24V

Impellers & Gaskets

360010	Impeller (Nitrile) use for oil or water transfer
360014	Impeller (Fluoroelastomer) use for diesel fuel transfer & diesel engine oil
360120	Gasket for OP-6

Repair Kit: Impeller + Gasket Set

SRK-360	1 Oil/water set
SRK-370	1 Diesel/oil set

Rebuild Kits: Impeller + Gasket + Seals Set

SRK-361	1 Oil/water set
SRK-371	1 Diesel/oil set

Parts

360060	Cover Plate for OP- 6
360070	Brass Cam for OP- 6
36015	Fuse (15 amp slow burn)
360002	Pump Head Assembly
36003	3 - Way Toggle Switch (On-Off-On)

Ordering Specifications

Model _____ OP 70_ 12/24
 Pump _____
 # of valves _____
 Voltage _____

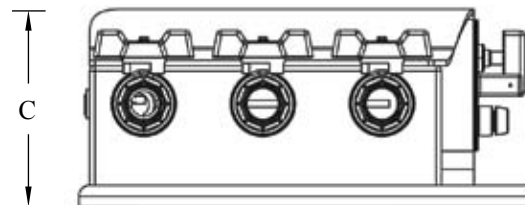
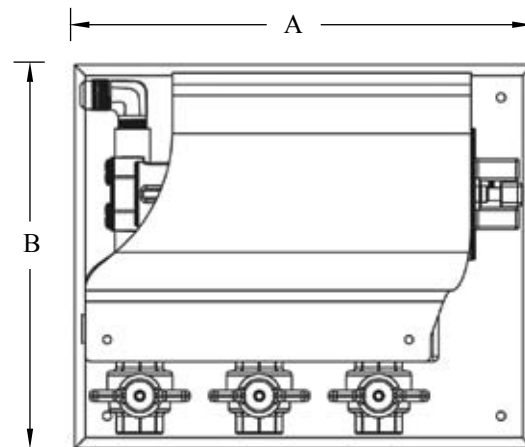

Drawing dimensions for reference only.
 Technical drawings available upon request.

Shown: OP-703-12

Model	A	B	C	Weight
OP-702	9.6" (244.5mm)	8.8" (223.9mm)	4.55" (115.6mm)	10 lbs (4.5kg)
OP-703	10.6" (269.9mm)	8.8" (223.9mm)	4.55" (115.6mm)	11 lbs (5.0kg)
OP-704	11.6" (295.3mm)	8.8" (223.9mm)	4.55" (115.6mm)	12 lbs (5.5kg)
OP-705	14.3" (362mm)	8.8" (223.9mm)	4.55" (115.6mm)	13 lbs (5.9kg)
OP-706	16.3" (418.8mm)	8.8" (223.9mm)	4.55" (115.6mm)	15 lbs (6.8kg)