

### Multi-Functional Features

- Primary fuel water separator- Removes 99.9% of water  
(Certified TUV Report using SAE J1839)
- In-line manual fuel primer
- Drain/fill oil change system
- Environmentally responsible
- Minimal fuel flow restriction

### Benefits

- Protects engine and augments reliability
- Reduces priming time
- Saves time on maintenance
- Reduces waste stream and risk of oil spillage
- Pumps oil into and out of engine
- Increases fuel system component life

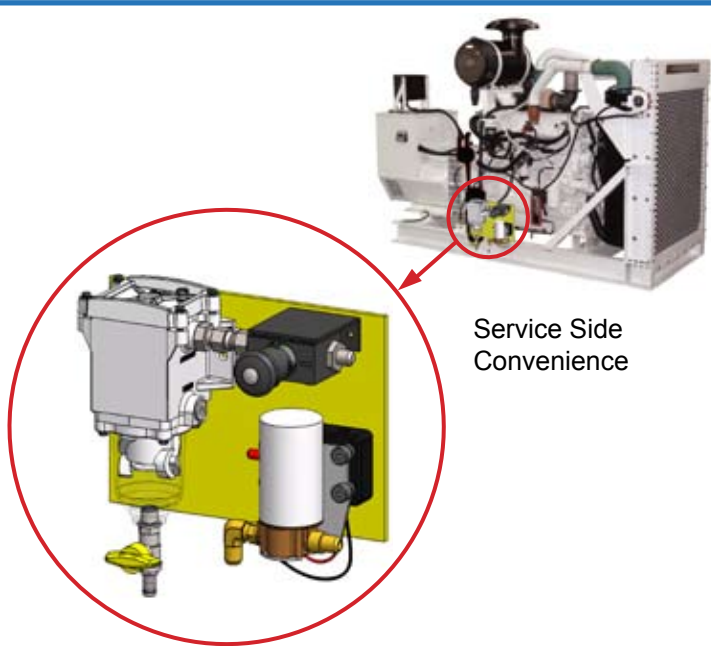

Service Side Convenience



A

4" Minimum height required for filter servicing

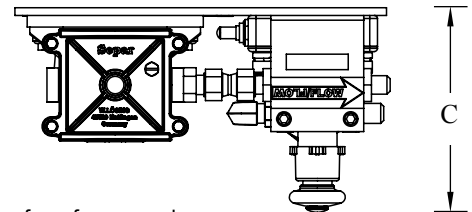
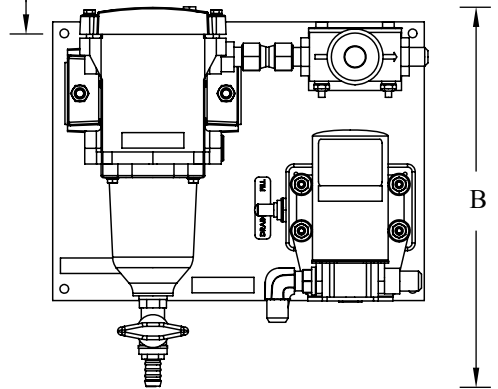

Drawing dimensions for reference only. Technical drawings available upon request.

### Technical Specification

Filter	
Element	30 Micron
Flow Rate	79 GPH (299 LPH)
Inlet	#8 O-Ring Boss
Marine Version	Includes bowl w/ heat shield
Oil Change System - Fills and Drains	
Ports	1/2" Male JIC
Flow Rate	3 GPM (11.3 LPM)
Self Priming	5 ft (1.5 m) (wet gears)
Primer	
Operating temp. range	-40°C to +120°C
Flow	.85 oz (25 mL) per stroke
Pressure	develops 100 psi (7 bar)
Internal Diameter (I.D.)	1/2"
Fitting size	1/2" Male JIC

Model	A	B	C	Weight
SC-550-311-12	12" (304.8mm)	12.25" (311.2mm)	6.52" (165.6mm)	13 lbs (5.9kg)